

SORRCA RULES

07 DEC 2022 Edition
Living Rules

CONTENTS

What is new for 2023 5

revision notes - 23NOV2022 6

the Living Rules Process 7

 What is it?..... 7

 How does it work?..... 7

 Change Frequency 7

 Words matter 7

Safe and fair competition statement 8

General Vehicle SPECIFICATIONS 9

 Tires 11

 Modification – Please see each class for more specifics 11

 Ban List 11

The rectangle 12

Class 1 13

 Requirements 13

 Overall Rectangle 13

 Center Rectangle Section 13

 Front Rectangle Section 14

 Rear Rectangle Section 14

 Chassis 14

 Steering 14

 Body requirements..... 14

 Regular Beds / Pick-up box 15

 flat bed 15

 Tube bed..... 15

 Windshield..... 15

 Bumpers 15

 Tires 16

 Prohibited Mods..... 16

 Drawing 17

Class 2 20

 Requirements 20

 Overall Rectangle 20

 Center Rectangle Section 20

SORRCA RULES 2023

Front Rectangle Section 21

Rear Rectangle Section 21

Chassis 21

Steering 21

Body requirements..... 21

Windshield..... 21

Bumper(s) 22

regular bed / Pick-up Box..... 22

Truggy back 22

Tube bed..... 22

flat bed 22

Tires 23

Prohibited Mods..... 23

Drawing 24

Class 3 27

Requirements 27

Overall Rectangle 27

Center Rectangle Section 27

Front Rectangle Section 27

Rear Rectangle Section 28

Chassis 28

Steering 28

Body requirements..... 28

Windshield..... 28

Bumper(s) 28

regular bed / Pick-up Box..... 29

Truggy back 29

Tube bed..... 29

flat bed 29

Tires 30

Other Allowed Mods 30

Drawing 31

Scale Points..... 34

Body..... 34

Hard body 34

INNER WHEEL WELLS..... 35

SORRCA RULES 2023

BED	35
Drop Bed.....	35
Flatbed.....	36
Tube Bed	36
Roll Bar or Headache Rack	36
Tubers, Truggies	36
Truggy.....	36
Tube frame	37
Rigid flat metal/plastic metal BODY PANELS	37
Interior and/or Exo Cage	37
tube / plate accessories	38
sliders	38
bumpers	38
stinger / grill guard	38
Fabricated Shock Mounts	39
Roof rack.....	39
Light bar	39
Interior.....	39
Full interior	39
interior cover.....	40
suv cargo area	40
driver/passenger	40
Suspension, Drivetrain, and Steering.....	40
leaf springs	40
multiple driven axles	41
chassis mounted steering servo.....	41
Functioning transfer case	41
3d engine.....	41
Scale Accessories.....	41
spare tire(s)	42
Course Points.....	43
Gate Progress (-2 points)	43
Bonus Gate Progress (-5 points)	43
Reverse (+1 point).....	44
SELF-RECOVERY (+3 POINTS).....	44
Rollover (+5 points).....	44

SORRCA RULES 2023

Gate Marker (+10 points).....	45
BOUNDARY MARKER (+10 POINTS)	45
Course Direction (+10 points)	45
Assisted Recovery (+10 points)	46
Winch stick	46
Vehicle Touch (+10 points).....	47
Reposition (+10 points)	47
On-Course Repairs (+10 points)	47
Off-Course Repairs (+10 points and 1 Minute).....	48
Safety (Time Out)	48
Vehicle out-of-spec (time out)	48
Point out (+80 Points)	49
DNF (DID NOT FINISH) (POINT OUT +20 POINTS).....	49
DNS (DID NOT START) (POINT OUT +50 POINTS).....	49

WHAT IS NEW FOR 2023

We have worked hard to change the rules and as such many changes exist in this document. Please read the whole thing carefully as some changes come down to minor wording. The big changes we want to share are as follows.

1. New rules format
2. Rectangle
3. The Living Rules Process
4. No local override – Modified SORRCA
5. Classes changed
6. Points revamped

1. Living rules change frequency further clarified
 - Page 7
2. Safe and fair competition statement
 - Page 8
3. Body, T-case, Bead lock General Vehicle Specifications changes
 - Page 9
4. Static Ride Height replaced with Full Compression
 - Page 10
5. Tiers – line deletion
 - Page 11
6. Further clarification of the rectangle
 - Page 12
7. C1 advice on how to read the current rules, 2x3 criteria added, and more
 - Pages 13-15
8. C2 rule clarification on rear bumpers, change to body height, and extended center section
 - Pages 20-23
9. C3 rule clarification on bumpers, center section, and shocks
 - Pages 27-30
10. Scale Points definition and point adjustments
 - Pages 34-42
11. Course points, Winch stick, progress, etc
 - Page 42-49
12. General updates to drawings for clarity
 - See all drawings

THE LIVING RULES PROCESS

WHAT IS IT?

To ensure fair competition and clarify the rule set SORRCA is making amendments that will allow all types of builds and creativity while keeping the playing field equal across the classes.

The spirit of competition and fair play is of paramount importance to us. There is no feasible way to write rules that prevent all loopholes or grey area abuse. It's just not possible. With that said, the new living rules process will be the way forward.

HOW DOES IT WORK?

1. Event hosts reach out to the committee to report concerns via question on the official [feedback form](#)
2. The committee will review the concern and make a ruling
3. If the concern requires action, we will update the rules and publish a new version for the public
4. The new rules will go into effect after the ruling is made public and the new rules version will be dated to indicate when it goes live
5. All rule changes will be frozen 60 days prior to Nationals and will be updated again as needed after

CHANGE FREQUENCY

Minor changes: The living rules will be updated to add clarification and minor wording fixes as needed. This is to prevent Facebook from becoming a knowledge base for answers. If we can't quote the rules the rules are wrong.

Major Changes: Updates that are considered major should be far and few between. These are sport breaking issues that must be fixed to ensure fair competition. Ideally this never happens, but time will tell. If a major change does have to occur, we will allow ample time to accommodate the change(s). Due to not knowing the scope of the changes ahead of time we can't predict what ample time is, but we will ensure you always have a logical amount of time to address any changes.

Rest assured that you need not worry about yearly overhauls or vast and rapid changes with this process. We will be more stable and no longer having to wait for a yearly drop. We on the board are not trying to get you or us to rebuild our trucks every other month. We don't have the appetite for that as we assume you don't either.

WORDS MATTER

With this new process we will be strictly following what is written in the latest version of the rules. Rulings or conversations from Facebook, Facebook Messenger, screenshots, smoke signals, or your 3rd cousins' best friend Bob who went to school with your wife's cousin will all be irrelevant now. Read humor and sarcasm because this is supposed to be fun!

SAFE AND FAIR COMPETITION STATEMENT

The rules set forth are for maintaining safe and fair competition for all participants. The location of scale crawling competitions is often in rugged terrain. In order for events to accommodate less abled participants, local event hosts may accommodate less abled participants with certain aspects of the event. However, the event host must make it clear only those identified whom require assistance may use the accommodations to the event rules and be accepted by drivers at the drivers meeting.

GENERAL VEHICLE SPECIFICATIONS

Scale realism is encouraged, go above and beyond to make your vehicle as realistic as possible.

- **Vehicle, body, accessories, and scale items:**
 - Must resemble their 1:1 counterpart
 - Must be in the same scale and proportion to the vehicle
 - Must be appropriately mounted and positioned for its application
- **Class 1:** Requires a full rail or pan chassis setup
- **Class 2:** Requires a full rail, truggy-back, or pan chassis setup
- **Class 3:** Requires a full rail, truggy-back, tube chassis, or pan chassis setup
- **Motor on Axle:** MOA is not allowed in any class
- **Axles:**
 - Must be shaft driven by a single motor that is chassis mounted
 - More than two axles are allowed in all classes
 - Over / under drive gears are allowed in all classes
 - Any axles ahead of the center of the vehicle are allowed to be steering axles in all classes
 - Rear Steer (any axle behind the center of the vehicle)
 - **ONLY** allowed in Class 3
- **Transmission:**
 - Dig and selectable over/under drives are **ONLY** allowed in Class 3
 - Multiple methods can be installed and used at the same time in Class 3
- **Transfer case:**
 - points are awarded when a transmission is present that has gear reduction from the motor and a different set of gears is dividing the power to the axles
 - Standalone factory 3 gear transmissions do not count for transfer case points
- **Wheels:** 2.2" maximum size for any class
- **Max Bead lock ring diameter:** 2.55" (64.77mm)
- **Weights:** No bolt-on or stick-on weights can be used on the axles or knuckles
 - Any visible weight must resemble a scale item or be an integral part of the truck
 - Examples:
 - If knuckles have additional weight options, you will not be allowed to run them with the additional weight installed
 - Swapping factory plastic or metal components with direct replacement components made of heavier materials such as brass or steel is permitted
- **Electronics:**
 - Electronics (except for servos) must be covered and hidden from view when viewed from any angle while sitting on all tires

- All motors, transmissions, and other electronics (other than steering servos) must be chassis, frame, or body mounted
- **Winching:** Can only be performed from natural terrain, objects that are part of the course, other vehicles, or winch sticks supplied by the event host
- **Recovery Items:**
 - Any recovery tools must be present on the vehicle prior to tech in to be used on course
 - Recovery tools must be on the vehicle prior to course start and returned to the vehicle after each use
 - Examples: Tow straps, pull palls, sand landers, etc.
- **Body:**
 - A body is required as defined in each class specifications
 - Points are defined in the scale points section
 - If the roof of the vehicle is removed, an interior or interior cover is required
- **Full Compression :** The method used to check parameters for width and height as required for tech-in - To determine Full Compression:
 1. Set your vehicle on a flat surface with all steerable tires pointed straight
 2. Push down until full compression is achieved
 3. This will be the full compression for tech table inspection

TIRES

MODIFICATION – PLEASE SEE EACH CLASS FOR MORE SPECIFICS

- Class 1
 - 4.19" (106.4mm) maximum diameter
 - No external tire modification is allowed
- Class 2
 - 4.20" (106.68mm) minimum diameter
 - 4.75" (120.7mm) maximum diameter
 - Tire lugs may be removed, siped, grooved and/or trimmed
- Class 3
 - 4.76" (120.9mm) minimum diameter
 - 6.0" (152.4mm) maximum diameter
 - Lugs may be removed, siped, grooved and/or trimmed
 - Tires may be cut and shut, all tire parts must be from a legal tire
- All diameters as per manufacturer's specification. Any tire without a manufacturer's specification will be measured off the vehicle flat on a table.

BAN LIST

- All pin pattern tires and tires intended for WRCCA or similar competition
- Losi Claws, Boss Claws and Rock Carvers
- Hot Bodies Rovers and Sedonas
- HPI Rock Grabbers
- Panther Cougars and Leopards
- Pro-Line Chisels
- Pro-Line Ibex
- RC4WD X-Locks, Crazy Crawlers and Bully Pins
- Imex Skulls and Bones
- JConcepts Ruptures
- Dlux Goats

THE RECTANGLE

Please read the rectangle sections as written and don't apply your old knowledge from previous rules. If it's not written down as prohibited then it is allowed. If it's written as "must be" then that is how it "must be". We want creativity and have created areas to go wild in, but have some mandated features for each class. The rectangles are imaginary boundaries where rules are applied, don't confuse this as your body defining the boxes.

The rectangle or rectangles are a new introduction to a reference-based set of parameters for each class specifications. Each rectangle consists of three sections with unique requirements. This allows the builder to open their range of realism and creativity.

Each class will have a basic set of parameters based on the rectangle(s) that represent the class. If the build parameters of your rig meet or exceed the minimum class rectangle(s), it will meet specification.

All criteria of the rectangle must be met either by body dimensions, the use of bumpers, cage work, or sliders. Skid, stinger, fairleads, shackles, roof racks etc... are not included in this measurement. Rigs that do not meet the rectangle criteria will not be allowed. Note that there are special requirements for full hard body points, please see that section for full details.

ALL REFERENCE MEASUREMENTS FOR EACH CLASS SPECIFICATION WILL BE MADE FROM THE VEHICLE AT FULL COMPRESSION

CLASS 1

Class 1 is your typical daily driver with a typically recognized body style that is complete in chassis form and structure

REQUIREMENTS

- Gates minimum width: 11 inches
- Maximum points: 60

OVERALL RECTANGLE

The rectangle specification for Class 1 will be subdivided into three sections the front, center, and rear.

All criteria of the rectangle must be met either by body dimensions, the use of bumpers, cage work, or sliders.

- Skid, stinger, fairleads, shackles, roof racks etc... are not included in this measurement

The dimensions of the vehicle must meet and/or exceed the following rectangle parameters as described.

Measured at full compression:

- Height: The body and or cage work must extend 0.5" above the tops of the tires in all rectangle sections at Full Compression
 - A cab (driver/passenger area) is required and must be at least 4.5" From the bottom edge of the body or sliders to the top of the body or cage work in the section the cab exists
 - A 2" by 3" horizontal section of body or cage work must be at or above the minimum height requirement where the cab exists
 - Measured perpendicularly from the tech table
 - The bottom edge of either the slider or body cannot be higher than the top of the wheel rims at Full Compression for the length of the center section
- Length: Must extend beyond the leading edge of the frontmost tire and the trailing edge of the rearmost tire
- Width: Must be at least as wide as the inside front tire track width measured from the top tire bulge to top tire bulge in all three sections

Please note that the major body mods rule has been removed – do not read these and apply the old rules, only go by what is written.

CENTER RECTANGLE SECTION

- Height: See overall rectangle height
- The bottom of the body or slider cannot be higher than the wheel rim at Full Compression
- Length: Center section starts and ends as follows:
 - 1" or less from the trailing edge of the front tire
 - 1" or less from the leading edge of the rear tire

- Width: See overall rectangle width
 - Measured no higher than at the top of the tire

FRONT RECTANGLE SECTION

- Height: See overall rectangle height
 - Stingers do not count in this measurement
- Length: Must be from the front of the center rectangle to at least the leading edge of the frontmost tire
- Width: See overall rectangle width

REAR RECTANGLE SECTION

- Height: See overall rectangle height
- Length: Must be from the rear of the center rectangle at least to the trailing edge of the rearmost tire
- Width: See overall rectangle width

CHASSIS

- No part of the chassis or suspension can be visible when they penetrate through the body
- Adjustable length chassis are allowed
- A skid plate is required and must be parallel to the body's rocker panels

STEERING

- Vehicle must have a Chassis Mounted Steering servo (CMS) setup
- Axle mounted steering servo of any kind is not allowed in Class 1
- Rear steer not allowed
 - If present it must have a mechanical lockout.

BODY REQUIREMENTS

- No part of the chassis or suspension can be visible when they penetrate through the body
- Body mounted bumpers may be replaced with chassis mounted bumpers
- Bodies must be mounted in a realistic position as you would expect in a full-size vehicle
 - Axles must be centered in the wheel wells
 - A deviation of .5" combined maximum is allowed
 - Acceptable examples
 - Front axle can be .5" off center if the rear axle is centered
 - Rear axle and front axle can be .25" each off center
 - Unacceptable examples
 - Either axle is over .5" off center of the wheel well
 - Front axle is .3" off center and rear is .25" off center

- Cab Only: is not allowed in Class 1. A truck style body must include a bed
 - Pick up box and flat decks/flatbeds are allowed
 - Tube bed and truggy-backs are not allowed

REGULAR BEDS / PICK-UP BOX

- See scale points section for details if present

FLAT BED

- Must meet the rectangle parameters
- Must have an outer perimeter structure at least .125" (3.2 mm) thick
- Must have complete deck/floor
 - Shock hoops and/or suspension must be covered if penetrating the bed or box

TUBE BED

A bed constructed of tube type material that mimic a pickup box bed (must have a depth component otherwise it's a flatbed)

- Must meet the rectangle parameters
- Must be attached to the frame at the left and right sides and rear of the chassis with 4 points of connections to the frame
- Must have a complete lower horizontal perimeter structure
- Must have a three-sided upper perimeter structure (no tailgate bar needed)

WINDSHIELD

- A windshield must be present and must fill the entire window frame in a realistic position
- Base of the windshield must be within .5" of the width of the rectangle on each side

BUMPERS

- Front bumper is required (may be bolted/attached to the body or chassis mounted)
- Rear bumper is required (may be bolted/attached to the body or chassis mounted)
- Bumpers must be at least as wide as the respective rectangle parameters
 - Must have material as wide as the inside front track width below the tops of the tire
 - Vertical height of bumper material must be at least .125 inches (3.2mm)
 - Specified requirement must be beyond the body and tires (lengthwise).
 - Front bumper: any portion that is above the top of the tire or behind the body, chassis or leading edge of front tire will not count toward the required specification of the bumper
 - Rear bumper: any portion that is above the top of the tire or in front of the body, chassis or trailing edge of the rear tire will not count toward the required specification of the bumper
- All measurements are taken at full compression

SORRCA RULES 2023

- Bumpers that are a part of the body mold qualify if they meet spec
 - Molded body bumpers may be replaced with chassis mounted bumpers
 - Tires may not extend beyond the front or rear bumper
 - No stinger, fairleads, shackles, etc. count for this measurement
-

TIRES

- Maximum tire size: 4.19" (106.4mm) per manufacturers specification
 - Any tire without a manufacturer's specification will be measured off the vehicle flat on a table
 - No external tire modification is allowed
 - See "General Tire section" for details
-

PROHIBITED MODS

- Rear steer
 - Any rear steer rig must have a mechanical lock-out so the rear wheels cannot turn
- Dig / Selectable Over-drive
 - Any dig or selectable overdrive must have a mechanical lock-out to prevent engagement

CLASS I TOP VIEW

SLIDERS

- * Must protect the bottom edge of the body
- * Must be the entire length of the center rectangle section

BODY(When viewed from above):

- * Must extend to or exceed ALL RECTANGLE SECTIONS in width and length
- * **WIDTH** - From inside front track width in all rectangle sections
- * **LENGTH** - Starts at the the center section and must extend at least to the leading edge of the front tire and trailing edge of the rear tire

FRONT BUMPER:
Must extend beyond the body and tires

REAR BUMPER:
Must extend beyond the body and tires

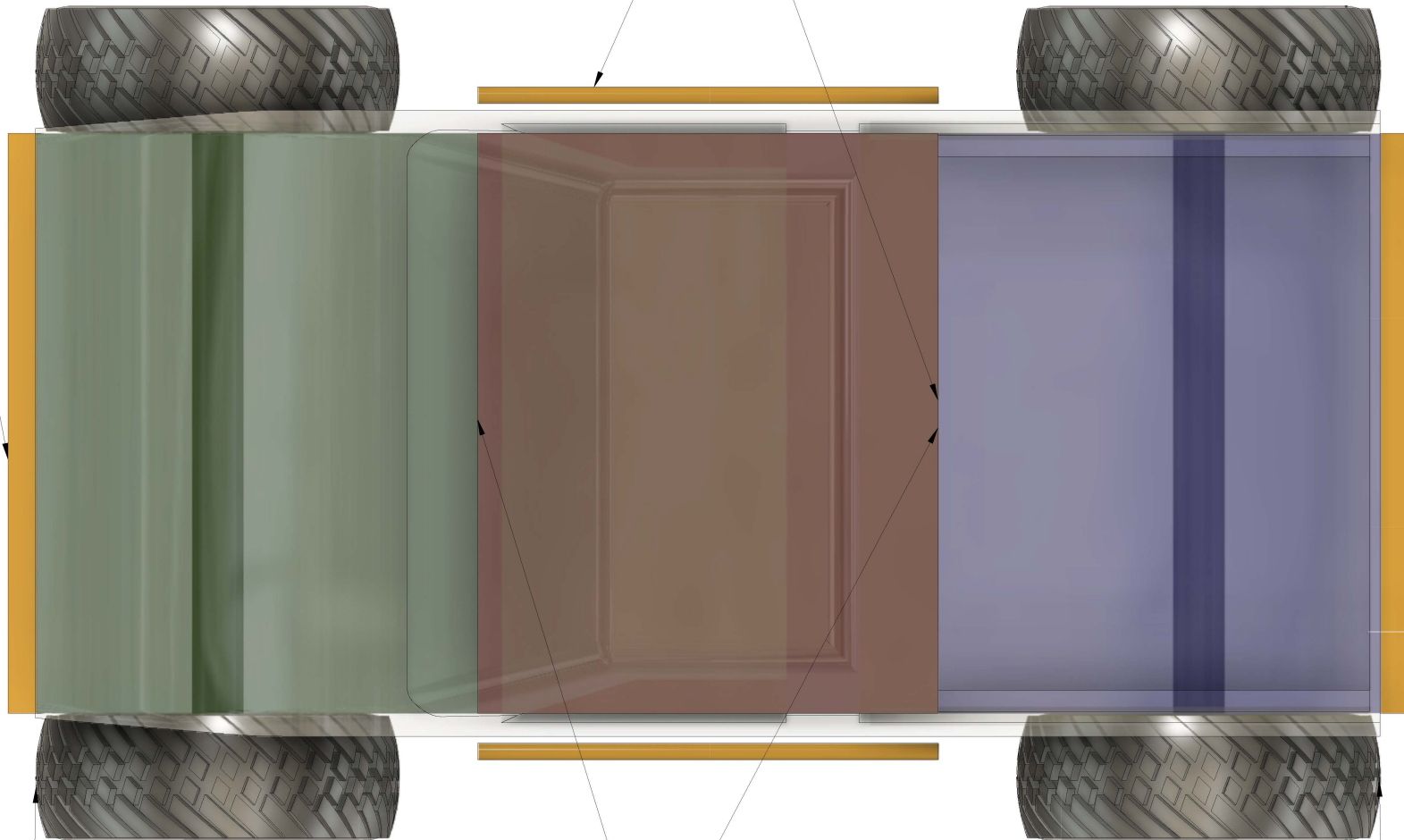

LEADING EDGE

TRAILING EDGE

OVERALL HEIGHT
* A 2' by 3' horizontal section of body or cage work must be at or above the minimum height requirement where the cab exists

[Return to Contents](#)

SORRCA 2022	Domin Hamold 11/16/2022	SORRCA	2022-11-26
Class 1 New Mod		C1-2023-TOP	1/1

CLASS 1 FRONT VIEW

WINDSHIELD (Required):
* Must be within 0.5" (12.7mm) of the rectangle edge at the widest point where the cab exists.

TIRES:
Maximum diameter 4.19 inches (106.5mm)
as per manufacturers specification

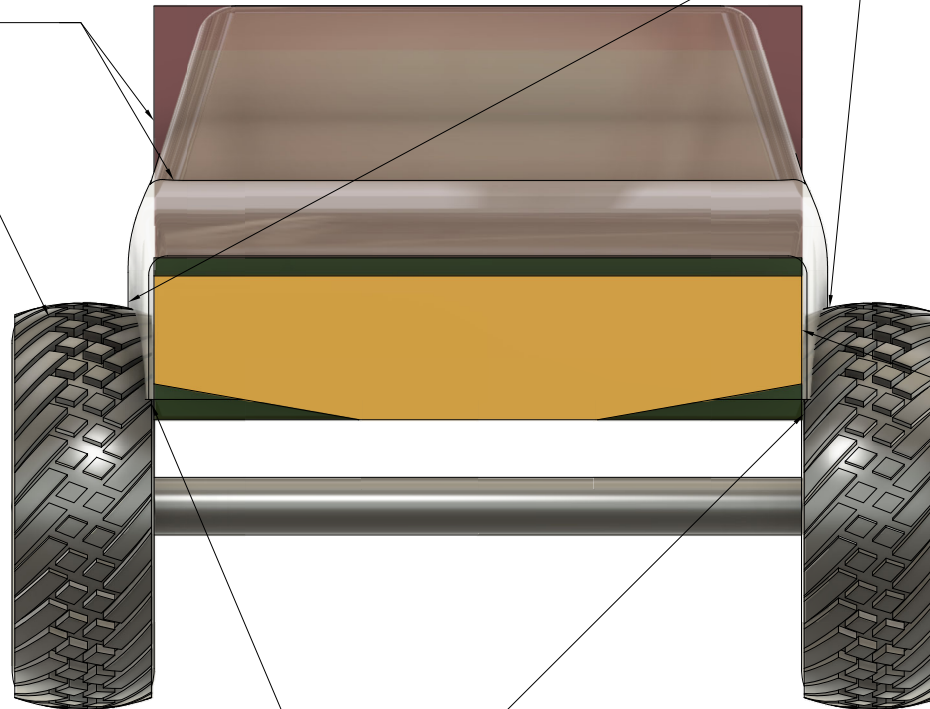

ALL RECTANGLE SECTIONS:
* **WIDTH** - Body or sliders must be at least as wide as the inside front track width
* Measured at full compression

FRONT AND REAR BUMPERS (Required):
Must meet specification at full compression

* Must have material as wide as the inside front track width below the tops of the tire
* Vertical height of bumper material must be at least .125 inches (3.2mm)
* Specified requirement must be beyond the body and tires (lengthwise).

NOTE: The required portion of the bumper must meet the above specifications

WIDTH REFERENCE MEASUREMENT:
* Is the front inside track width measured from top tire buldge to top tire buldge

[Return to Contents](#)

Year	2023 Rules	Author	Darren Hamaoki 11/16/2022	Organization	SCRRCA	Version	2022/11/16
		Title	Class 1 New Mod			Page	1/1
		Doc. #	C1-2023-Front			Page	2

CLASS 1 SIDE VIEW

CENTER RECTANGLE (When viewed from the side):
 * HEIGHT- Body must extend at least 0.5 inch f12.7mm) above the tops of the tires at full compression

OVERALL HEIGHT:
 * Must be at least 4.5 inches f114.3mm) from the bottom edge of the of the body or slider to the top of the cab or cagework in the section the cab exists
 (MEASURED PERPENDICULAR TO THE TECH TABLE)

FRONT RECTANGLE (When viewed from the side):
 * HEIGHT- Body must extend at least 0.5 inches f12.7mm) above the tops of the tires at full compression
 * LENGTH - Must extend at least to the leading edge of the front tires

REAR RECTANGLE (When viewed from the side):
 * HEIGHT- Body must extend at least 0.5 inches f12.7mm) above the tops of the tires at full compression
 * LENGTH - Must extend at least to the trailing edge of the rear tires

FRONT BUMPER: (Required)
 * Must extend beyond the body and tires

REAR BUMPER: (Required)
 * Must extend beyond the body and tires

CENTER RECTANGLE:
 * LENGTH - Body or slider must be within 1 inch (25.4mm) from the trailing edge of the front tire and the leading edge of the rear tire respectively

Body or slider must be below the tops of the wheel rim at full compression for the entire length of the center rectangle

LEADING EDGE

TRAILING EDGE

LEADING EDGE

TRAILING EDGE

Body must be centered over wheel wells within 0.5inch (12.7mm) total misalignment

CLASS 2

Class 2 is your modified truck or 4X4 purpose built for heavy off-road use. Typically using recognized body style that has possibly undergone modifications and customization in chassis form and structure to achieve this

REQUIREMENTS

- Gate minimum width: 12 inches
- Maximum points: 50

OVERALL RECTANGLE

The rectangle specification for Class 2 will be subdivided into three sections the front, center, and rear.

All criteria of the rectangle must be met either by body dimensions, the use of bumpers, cage work, or sliders.

- Skid, stinger, fairleads, shackles, roof racks etc... are not included in this measurement.

The dimensions of the vehicle must meet and/or exceed the following rectangle parameters as described
Measured at full compression:

- Height: Body and or cage work of all rectangle sections must extend higher than the tops of the tires at Full Compression
 - A cab (driver/passenger area) is required and must be at least 4.25" From the bottom edge of the body or sliders to the top of the body or cage work (if roof is removed) in the section the cab exist
 - A 2" by 3" horizontal section of body or cage work must be at or above the minimum height requirement where the cab exists
 - Measured perpendicularly from the tech table
 - The bottom edge of either the slider or body cannot be higher than the top of the wheel rims at Full Compression for the length of the center section
- Length: The overall length and coverage must be at least to the leading edge of the frontmost wheel rim to the trailing edge of the rearmost wheel rim
- Width: Defined in each section

CENTER RECTANGLE SECTION

- Height: See overall rectangle height
- The bottom of the body or slider cannot be higher than the wheel rim at Full Compression
- Length: Center section starts and ends as follows:
 - 2" or less from the trailing edge of the front tire
 - 2" or less from the leading edge of the rear tire
- Width: Must be at least as wide as the inside of the front tire track width for its entire length of the center section
- Width: See overall rectangle width

- Measured no higher than at the top of the tire

FRONT RECTANGLE SECTION

- Height: See overall rectangle height
 - Stingers do not count in this measurement
- Length: Must be from the front of the center rectangle to at least the leading edge of the frontmost wheel rim
- Width: Must be at least $\frac{1}{2}$ of the width of the total center rectangle at the narrowest
- Taper: The Front section can have a realistic taper (pinch) from the center section to the front
 - Taper must be at least a straight line from the edge of center rectangle width to the front section width when viewed from above

REAR RECTANGLE SECTION

- Height: See overall rectangle height
 - Shock towers do not count in this measurement
- Length: Must be from the rear of the center rectangle at least to the trailing edge of the rearmost wheel rim
- Width: Must be at least $\frac{1}{2}$ of the width of the total center rectangle

CHASSIS

You can run the following chassis types in Class 2

- Full rail chassis
- Pan chassis
- Truggy-back (so long as the truggy-back meets the rectangle requirements)

STEERING

- Axle mounted steering (AMS) is allowed
- A Chassis Mounted Steering servo (CMS) is allowed
- Rear steer not allowed
 - If present it must have a mechanical lockout

BODY REQUIREMENTS

- Bodies must be mounted in a realistic position, as you would expect in a full-size vehicle
- Cab only is allowed, but must meet all rectangle requirements

WINDSHIELD

- A windshield is not required

BUMPER(S)

- Front bumper is required and must be chassis mounted
- Rear bumper is optional (must be chassis mounted and meet below specification for scale points)
- Bumpers must be at least as wide as the respective rectangle parameters
 - Must have material at least as wide as $\frac{1}{2}$ of the center section below the tops of the tires at full compression
 - Vertical height of bumper material must be at least .125 inches (3.2mm)
 - Specified requirement must be beyond the body and wheel rim (lengthwise)
 - Front bumper: any portion that is above the top of the tire or behind the body or chassis will not count toward the required specification of the bumper
 - Rear bumper: any portion that is above the top of the tire or in front of the body or chassis will not count toward the required specification of the bumper for scale points
- All measurements are taken at full compression
- bumper material must be a minimum of .125" or 3.2 mm in vertical height (for the required rectangle width)

REGULAR BED / PICK-UP BOX

- See scale points section for details if present

TRUGGY BACK

- The ladder frame rail must be removed behind the back of the cab and replaced with cage/tubing structure
- The Truggy-back must meet the Rectangle parameters
- The Truggy-back must have a roll bar hoop and integrated shock mounts
 - A roll bar hoop must be within $\frac{1}{8}$ " of the top of the cab
- Must be a structural part of the vehicle's chassis

TUBE BED

A bed constructed of tube type material that mimic a pickup box bed (must have a depth component otherwise it's a flatbed)

- Must meet the rectangle parameters
- Must be attached to the frame at the left and right sides and rear of the chassis with 4 points of connections to the frame
- Must have a complete lower horizontal perimeter structure
- Must have a three-sided upper perimeter structure (no tailgate bar needed)

FLAT BED

- Must meet the rectangle parameters

SORRCA RULES 2023

- Must have an outer perimeter structure with a minimum height of 1/8" (3.2mm)
 - Must have a complete deck
-

TIRES

- Minimum tire diameter is 4.20" (106.4mm) per manufacturers specification
 - Maximum tire diameter is 4.75" (120.7mm) per manufacturers specification
 - Any tire without a manufacturer's specification will be measured off the vehicle flat on a table
 - Tire treads may be removed, siped, grooved and/or trimmed
 - Tires cannot be cut, shut, narrowed, or made up of different tires
 - See "General Tire section" for details
-

PROHIBITED MODS

Rear steer

- Any rear steer rig must have a mechanical lock-out so the rear wheels cannot turn

Dig / Selectable Over-drive

- Any dig or selectable overdrive must have a mechanical lock-out to prevent engagement

CLASS 2 TOP VIEW

SLIDERS

- * Must protect the bottom edge of the body
- * Must at least be the entire length of the center rectangle section

REAR RECTANGLE (When viewed from above):

- * WIDTH: Must be at least $\frac{1}{2}$ the center rectangle
- * LENGTH: Starts at the back of the center rectangle and extends to at least the trailing edge of the rear wheel rim

FRONT BUMPER (Required):

- * Must extend beyond the body and leading edge of the front wheel rim (lengthwise)
- * Must be at least $\frac{1}{2}$ the width of the center rectangle section

REAR BUMPER (Optional - for scale points):

- * Must extend beyond the body and trailing edge of rear wheel rim
- * Must be at least as wide as $\frac{1}{2}$ the center rectangle

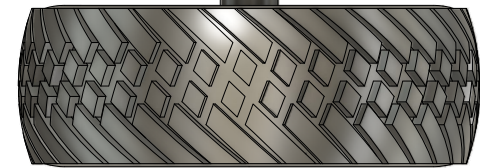
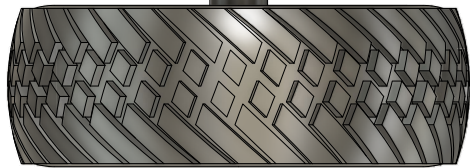
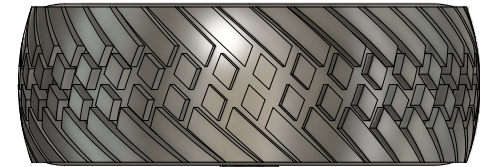
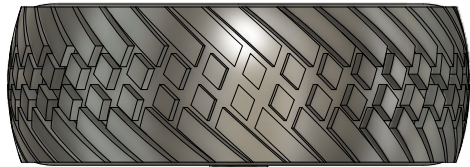

FRONT RECTANGLE SECTION (When viewed from above):

- * WIDTH - Must be at least $\frac{1}{2}$ the width of the center rectangle at the narrowest
- * TAPER - The front rectangle can have a realistic taper (pinch) from the center rectangle to the leading edge
 - * Taper must be at least a straight line from the center rectangle edge to the leading edge width
- * LENGTH - Starts at the front of the center rectangle and must extend at least to the leading edge of the front wheel rim

OVERALL HEIGHT

- * A 2" by 3" horizontal section of body or cage work must be at or above the minimum height requirement where the cab exists

[Return to Contents](#)

DATE	DESIGNED BY	DESIGNED FOR	DATE
	Darren Hamachi 2022-11-29		
TITLE		SCALE	
Class 2 New		1/1	
NO.	DESCRIPTION	DATE	BY

CLASS 2 FRONT VIEW

CENTER RECTANGLE (Body or Sliders):
* **WIDTH** - Must be at least as wide as the inside front track width
* **Body width** measured no higher than the tops of the tires

FRONT BUMPER (and REAR BUMPER if present):
to meet specification and scale points

* Must have material at least as wide as $\frac{1}{2}$ of the center section below the tops of the tires at full compression
* Vertical height of bumper material must be at least .125 inches (3.2mm)
* Specified requirement must be beyond the body and wheel rim (lengthwise)

NOTE: The required portion of the bumper must meet the above specifications

TIRES:
* Maximum diameter 4.75 inches (120.7mm)
* Minimum diameter cannot be smaller than 4.20 inches (106.7mm)

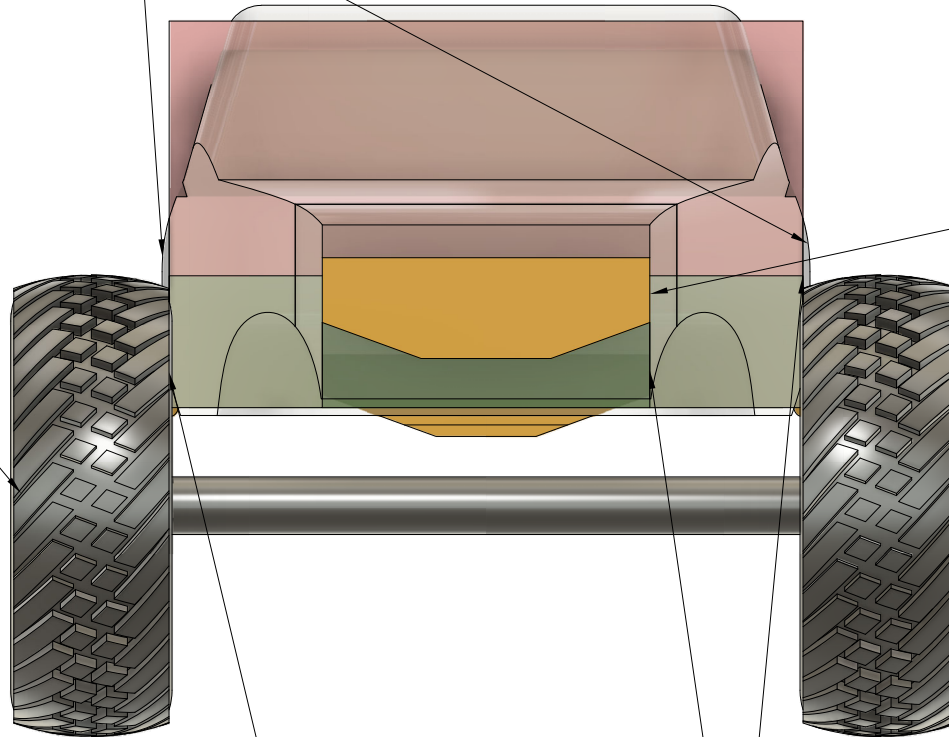

OVERALL WIDTH REFERENCE:
* The front inside track width measured at the top tire buldge to top tire buldge

FRONT RECTANGLE SECTION:
* May taper from the width of the center section to at least as wide as $\frac{1}{2}$ the inside front track width at its narrowest

[Return to Contents](#)

DATE	2022-11-28	DESIGNED BY	Darren Hamachi	REVISIONS	
TITLE	Class 2 New	DATE		NO.	
REV.		DATE		NO.	
1/1					

CLASS 2 SIDE VIEW

CENTER RECTANGLE (when viewed from the side):
 * HEIGHT - Body must extend at least to the tops of the tires at full compression

FRONT RECTANGLE (When viewed from the side):
 * HEIGHT - Must extend at least to the tops of the tires at full compression
 * LENGTH - Must extend at least to the leading edge of the front wheel rim

FRONT BUMPER (required):
 * Must extend beyond the body and leading edge of front wheel rim

**WHEEL RIM:
TOP EDGE**

**WHEEL RIM:
LEADING EDGE**

**FRONT TIRE
TRAIL EDGE**

CENTER RECTANGLE (length):
 * Must be within 2 inches (50.8mm) of the trailing edge of the front tire and the leading edge of the rear tire

Body or slider must be below the tops of the wheel rims at full compression for the entire length of the center rectangle

**REAR TIRE
LEADING EDGE**

OVERALL HEIGHT:
 * Must be at least 4.25 inches (108 MM) from the bottom edge of the body or slider to the top of the cab or cage work, in the section the cab exists (MEASURED PERPENDICULAR TO THE TECH TABLE)

REAR RECTANGLE(When viewed from the side):
 * HEIGHT - Body must extend at least to the top of the tires at full compression
 * LENGTH - Must extend to at least the trailing edge of the rear wheel rim

REAR BUMPER (Optional):
 * Must extend beyond the body and trailing edge of the rear wheel rim, for scale points

**WHEEL RIM:
TRAILING EDGE**

[Return to contents](#)

DATE	DESIGNED BY	DESIGNED FOR	DATE
	Darren Hamachi 2022-11-28		
TITLE		SCALE	
Class 2 New		1/1	

CLASS 3

Class 3 is your all-out rock crawling machine. Often built from the ground up custom tube chassis or highly modified vehicle that is purpose built for nothing except rock crawling

REQUIREMENTS

- Gate minimum width: 16 inches
- Maximum points: 50

OVERALL RECTANGLE

The rectangle specification for Class 3 will be subdivided into three sections the front, center, and rear.

All criteria of the rectangle must be met either by body dimensions, the use of bumpers, cage work, or sliders.

- Skid, stinger, fairleads, shackles, roof racks etc... are not included in this measurement. Shocks can be visible at all times.

The dimensions of the vehicle must meet and/or exceed the following rectangle parameters as described Measured at full compression:

- Height: Top of any section can be below the tops of the tires at Full Compression however:
 - A cab (driver/passenger area) is required and must be at least 4.0" From the bottom edge of the body or sliders to the top of the body or cage work (if roof is removed) in the section the cab exists
 - * A 2" by 2" horizontal section of body or cage work must be at or above the minimum height requirement where the cab exists
 - Measured perpendicularly from the tech table
 - The bottom edge of either the slider or body cannot be higher than the top of the wheel rims at Full Compression for the length of the center section
- Length: The overall length and coverage must meet or exceed the length of the wheelbase
- Width: Must be at least ½ the width of the front inside track width from top tire bulge to tire bulge

CENTER RECTANGLE SECTION

- Height: See overall rectangle height
- Length: Center section starts and ends as follows:
 - 2" from the trailing edge of the front tire
 - 2" from the leading edge of the rear tire
- Width: See overall rectangle width
 - Measured no higher than at the top of the tire

FRONT RECTANGLE SECTION

- Height: See overall rectangle height
- Length: Front rectangle section starts at the back of the center rectangle and extends forward

- Can be any length so long as the total length of all the rectangle sections is equal to or greater than the vehicles wheelbase
- Width: Must be at least 1/3rd of the inside track width
 - Measured no higher than at the top of the tire

REAR RECTANGLE SECTION

- Height: See overall rectangle height
- Length: Rear rectangle section starts at the back of the center rectangle and extends rearward
 - Can be any length so long as the total length of all the rectangle sections is equal to or greater than the vehicles wheelbase
- Width: Must be at least 1/3rd of the inside track width
 - Measured no higher than at the top of the tire

CHASSIS

You can run the following chassis types in Class 3

- Full rail chassis
- Pan chassis
- Truggy-back (so long as the truggy-back meets the rectangle requirements)
- Tube chassis

STEERING

- Axle mounted steering (AMS) is allowed
- Rear steer is allowed
- Chassis Mounted Steering servo (CMS) is allowed

BODY REQUIREMENTS

- Body and/or chassis of the vehicle must meet the rectangle requirements
- Body must be mounted in a realistic position, as you would expect in a full-size vehicle
- Cab only is allowed, but must meet all rectangle requirements

WINDSHIELD

A windshield is not required

BUMPER(S)

- Front bumper is optional (must be chassis mounted and meet below specification for scale points)
- Rear bumper is optional (must be chassis mounted and meet below specification for scale points)

Bumpers must be at least as wide as the respective rectangle parameters

- Must have material at least $\frac{1}{3}$ the inside front track width below the tops of the tire at full compression
- Vertical height of bumper material must be at least .125 inches (3.2mm)
- Must extend beyond the rectangles
- Front bumper: any portion that is above the top of the tire or behind the body or chassis will not count toward the required specification of the bumper
- Rear bumper: any portion that is above the top of the tire or in front of the body or chassis will not count toward the required specification of the bumper
- All measurements are taken at full compression
- bumper material must be a minimum of .125" or 3.2 mm in vertical height (for the required rectangle width)

REGULAR BED / PICK-UP BOX

- See scale points section for details if present

TRUGGY BACK

- The ladder frame rail must be removed behind the back of the cab and replaced with cage/tubing structure
- The Truggy Back must meet the Rectangle parameters
- The Truggy must have a roll bar hoop and integrated shock mounts
 - A roll bar hoop must be within 1/8" of the top of the cab
- Must be a structural part of the vehicle's chassis

TUBE BED

A bed constructed of tube type material that mimic a pickup box bed (must have a depth component otherwise it's a flatbed)

- Must meet the rectangle parameters
- Must be attached to the frame at the left and right sides and rear of the chassis with 4 points of connections to the frame
- Must have a complete lower horizontal perimeter structure
- Must have a three-sided upper perimeter structure (no tailgate bar needed)

FLAT BED

- Must meet the rectangle parameters
- Must have an outer perimeter structure with a minimum height of 1/8"
- Must have a complete deck

TIRES

- Minimum Tire diameter is 4.76" (120.9mm) per manufacturers' specification
- Maximum Tire diameter is 6" (152.4mm) per manufacturers' specification
- Any tire without a manufacturer's specification will be measured off the vehicle flat on a table
- Lugs may be removed, siped, grooved and/or trimmed
- Tires may be cut and shut, all tire parts must be from a legal tire

OTHER ALLOWED MODS

Can all be used at the same time:

- Rear Steer
- Dig / Selectable Over-drive

CLASS 3 TOP VIEW

SLIDERS

- * Must protect the bottom edge of the body
- * Must at least be the entire length of the center rectangle section

REAR RECTANGLE (When viewed from above):

- * WIDTH - Must be at least $\frac{1}{3}$ the inside track width
- * LENGTH - Starts from the back of the center rectangle. Can be any length so long as the total length of all the rectangles is equal to or greater than the vehicles wheelbase

FRONT BUMPER (Optional for scale points):

- * Must extend in front of the front rectangle
- * Must be at least $\frac{1}{3}$ the front inside track width

REAR BUMPER (Optional for scale points):

- * Must extend beyond the rectangles
- * Must be at least $\frac{1}{3}$ the front inside track width

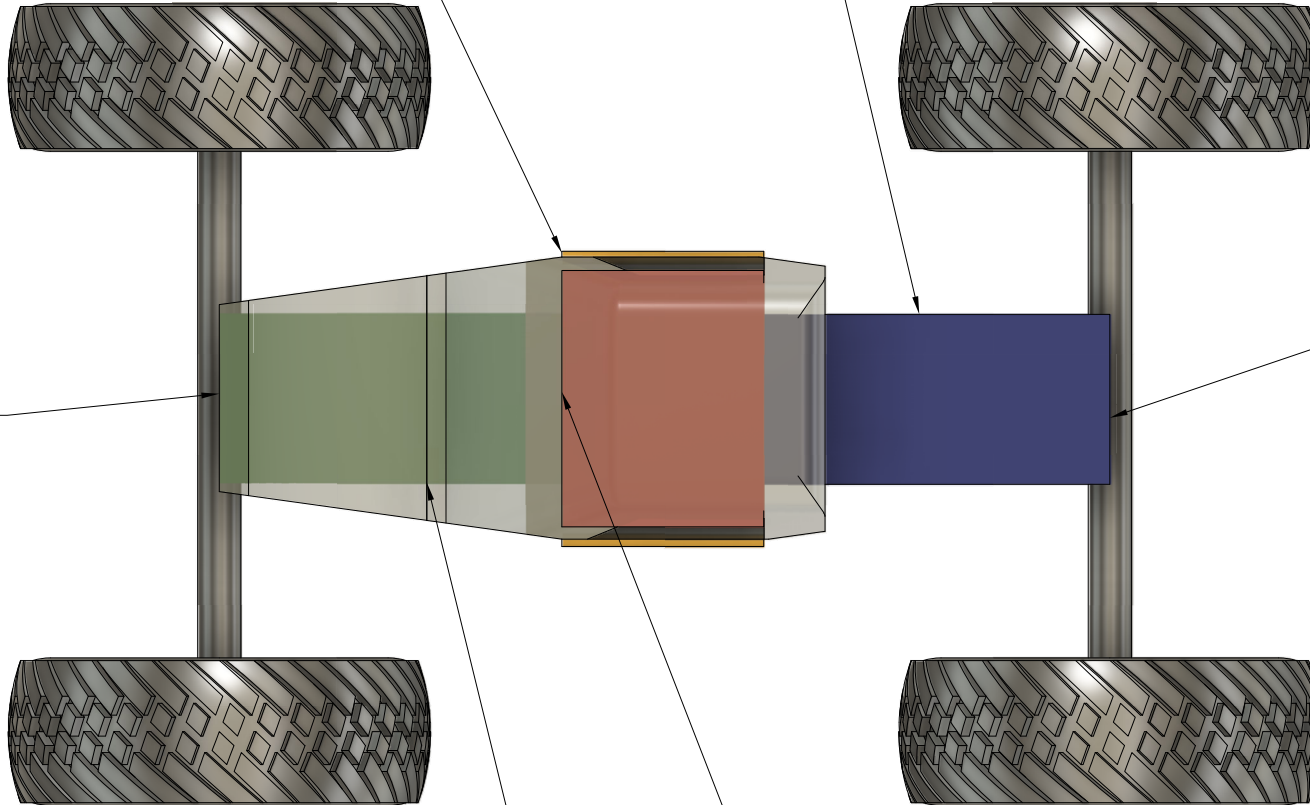

FRONT RECTANGLE (When viewed from above):

- * WIDTH - Must be at least $\frac{1}{3}$ the front inside track width
- * LENGTH - Starts at the front of the center rectangle. Can be any length so long as the total length of all the rectangles is equal to or greater than the vehicles wheelbase

OVERALL HEIGHT

- * A 2" by 2" horizontal section of body or cage work must be at or above the minimum height requirement where the cab exists

[Return to Contents](#)

DATE	DATE	REVISION	BY	APP
			Darren Hamachi 2022-12-03	
Title			Class 3 New Mod VER2	
Part			1/1	

CLASS 3 FRONT VIEW

CENTER RECTANGLE :

- * **WIDTH** - Must be at least $\frac{1}{2}$ the front inside track width
- * Measured no higher than the tops of the tires

BUMPERS (optional to receive scale points):

- * Must have material at least $\frac{1}{3}$ the inside front track width below the tops of the tire at full compression
- * Vertical height of bumper material must be at least .125 inches (3.2mm)
- * Must extend beyond the rectangles

Tires:
Maximum diameter 6.0 inches (152.4mm)

Minimum diameter cannot be smaller than 4.76 inches (121mm)

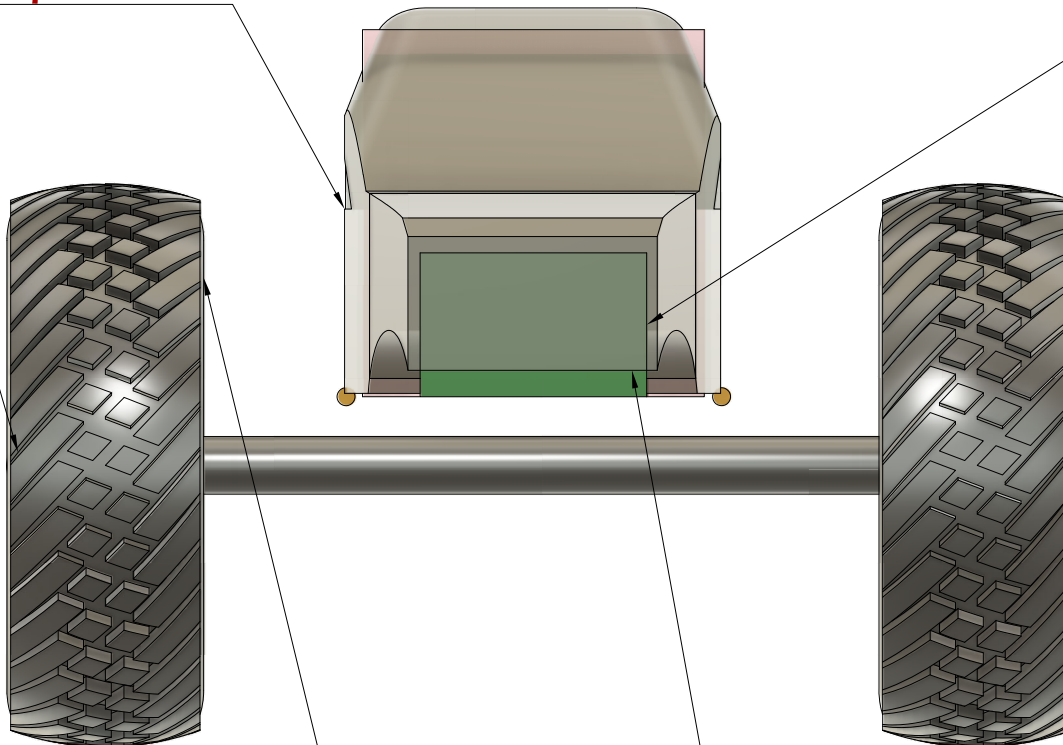

WIDTH REFERENCE MEASUREMENT:

- * Is the front inside track width measured from the top tire buldge to top tire buldge

FRONT AND REAR RECTANGLES:

- * **WIDTH** - Must be at least $\frac{1}{3}$ of the front inside track width
- * Measured at full compression
- * Measured no higher than the top of the tire

[Return to Contents](#)

Rev	Part #	Rev	Author	Date	Rev	Author
			Darren Hamanaki	11/29/2022		
Title			Description			
Class 3 New Mod VER2						
Rev	Author	Date	Rev	Author	Date	

CLASS 3 SIDE VIEW

CENTER RECTANGLE (When viewed from the side):
Height - Can be below the tops of the tires at full compression

OVERALL HEIGHT:
 * Must be at least 4.0 inches (101.6 MM) from the bottom edge of the body or slider to the top of the body or cage work where the cab exists (Measured perpendicular to the tech table)

FRONT RECTANGLE (When viewed from the side):
 * HEIGHT - Can be below the tops of the tires at full compression
 * LENGTH - Starts at the front of the center rectangle. Can be any length so long as the total length of all the rectangles is equal to or greater than the vehicles wheelbase

REAR RECTANGLE (When viewed from the side):
 * HEIGHT - Can be below the tops of the tires at full compression
 * LENGTH - Starts at the back of the center rectangle. Can be any length so long as the total length of all the rectangles is equal to or greater than the vehicles wheelbase

Top of wheel rim

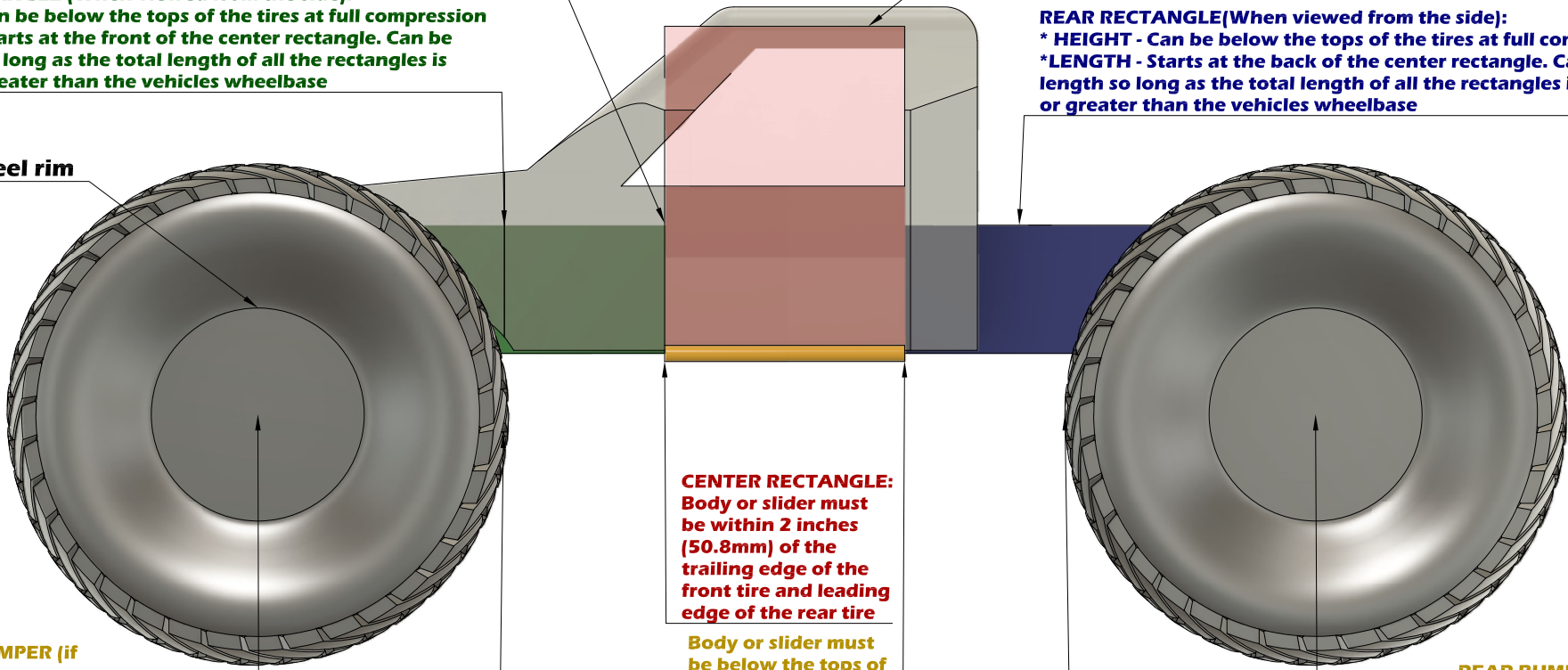

FRONT BUMPER (if present):
 Must extend beyond the front rectangle for scale points

Front tire:
Trailing edge

CENTER RECTANGLE:
 Body or slider must be within 2 inches (50.8mm) of the trailing edge of the front tire and leading edge of the rear tire

Body or slider must be below the tops of the wheel rim at full compression for the entire length of the center rectangle

Rear tire:
Leading edge

REAR BUMPER (if present):
 Must extend beyond the rear rectangle for scale points

Wheelbase

[Return to Contents](#)

DATE	DESIGNED BY	DESIGNED FOR	REVISED BY
	Darren Hamachi	2022-11-29	
	CLASS 3	NEW MOD	VER 2
			1/1

SCALE POINTS

- You cannot receive points for the same item multiple times under different categories
- You cannot receive multiple points for duplicate items unless specified
- All scale items are considered part of the rig as teched-in to the event
 - If any item falls off the rig while driving the vehicle is now considered out of spec and must be repaired
- Custom points are defined as anything scratch built in areas that define or allow custom points
 - Must have 3-dimensional body panels that cover the chassis (not flat panels that bolt in between visible tube work)
 - Must resemble a known 1:1 body and must be hand formed and fabricated from metal or other rigid material that meet the minimum specs
 - Absolutely NO cutting and re-gluing of pre-molded lexan/styrene interiors to gain additional custom points

BODY

HARD BODY

- Hard body points will be broken into each section of the rectangle
- A cab (driver/passenger area) is required and must be compliant with height requirement for the specific class
 - Measured from the bottom edge of the body or sliders to the top of the body or cage work (if roof is removed) in the section the cab exists
 - Measured perpendicularly from the tech table
- The body in each section must fill the rectangle when viewed from above
 - Bodies with insets grills or other oddities where the body does not fill the rectangle between the fenders can be covered by the bumper, winch plate or a vanity cover plate to fill the void
- The body in each section must be complete with body parts that fulfill the form and function of the body used:
 - Hood
 - Windshield cowl and/or firewall
 - Front fenders
 - Rear Fenders
 - Door frames (Front door jamb, Door sill, and rear door jamb)
 - Front Clip and/or rad support
 - Rear passenger compartment bulkhead or cab back
 - Roofline or cage-work (if roof is removed)
 - Pick-up Box (flat bed and Truggy-back, does not receive hardbody points)

SORRCA RULES 2023

- Tube cage buggy may receive hard body points if a body is present under or over the tube work
- Injection molded hard bodies that are made by a recognized manufacturer (Tamiya, RC4WD, Team Raffee Killer body, Boom Racing, etc)
- Metal bodies must have a finished thickness of .030
- Vacuum formed, forged, hand built, 3D printed
 - Must have a finished thickness of .060 with these processes to receive hardbody points
- These materials receive no hard body points regardless of spec:
 - Foam, lexan, corrugated plastic, cardboard, paper mâché, rubber, latex, balsa wood
 - More to be added as they are discovered or exploited

FRONT RECTANGLE: -4 POINTS OR -5 IF CUSTOM

CENTER SECTION: -4 POINTS OR -5 IF CUSTOM

REAR RECTANGLE: -4 POINTS OR -5 IF CUSTOM

INNER WHEEL WELLS

- Must cover and fill the area between the chassis and body

FRONT INNER WHEEL WELLS POINTS: -1

REAR INNER WHEEL WELLS POINTS: -1

BOTH ALLOWED FOR -2 POINTS TOTAL

BED

DROP BED

- Must meet or exceed the rectangle parameters per class
- Must have the majority of the floor intact with the exception of where the shock hoops protrude (body mounts don't count as protrusions)
 - C1 must have all protrusions covered and not visible to receive points
 - C2 must have all protrusions covered and not visible to receive points
 - C3 can have protrusions that are not covered and receive points
- Must have bed sides
- Inside of the box cannot exceed 0.5" (12.7mm) from the exterior bed sides
- Wheel wells maximum width 1" (25.4mm) from the inside wall of the bed
- Must be a minimum of 1.25" (31.8mm) deep from top of bed sides to top of entire floor

SORRCA RULES 2023

- Bed must be outside of the passenger area separated by a wall

POINTS: -3

FLATBED

- Must meet the rectangle parameters
- Must have an outer perimeter structure with a minimum height of 0.125" (3.2mm)
- Must have a complete deck

METAL PERIMETER FRAME POINTS: -2

PLASTIC PERIMETER FRAME POINTS: -1

TUBE BED

A bed constructed of tube type material

- Must meet the rectangle parameters
- Must have a depth component otherwise it's a flatbed
- Must be attached to the frame/body with a minimum of 4 points of connection
- Must have a complete lower horizontal perimeter structure
- Must have a three-sided upper perimeter structure (no tailgate bar needed)

METAL POINTS: -3

PLASTIC POINTS: -1

ROLL BAR OR HEADACHE RACK

- Must be fixed to the frame or rigid part of the body so that it cannot flex under the weight of the rig if rolled
- Height must be within 0.125" (3.2mm) of cab height
- Width must be within 0.25" (6.35mm) of interior bed side

METAL POINTS: -2

PLASTIC POINTS: -1

TUBERS, TRUGGIES

TRUGGY

- C2 and C3 only
 - The Truggy Back must meet the Rectangle parameters per class.
 - The frame behind the cab must be removed and replaced with Cage/Tubing structure
 - The Truggy must have a roll bar hoop that meets roll bar specification
-

SORRCA RULES 2023

- Must be a structural part of the vehicle's chassis
- Tube bed, roll bar, shock mount points not available in addition to truggy bed points

METAL POINTS: -4

PLASTIC POINTS: -2

TUBE FRAME

- C3 only
- Must meet the Class 3 rectangle requirements
- A tube chassis consists of a complete body structure where the all sections are comprised entirely of structural tube work
- Tube bed, roll bar, internal cage, shock mount, and Truggy points are not available in addition to tube chassis points

METAL POINTS: -8

PLASTIC POINTS: -4

RIGID FLAT METAL/PLASTIC METAL BODY PANELS

- Body panels that rely on a Tube frame for their shape
- Points only available for tube chassis and truggy-backs

POINTS: -1

INTERIOR AND/OR EXO CAGE

- Must meet the rectangle requirements for its class
- Interior cage mounting points must attach to the dash, floor, wheel well or the top of the interior cover
- Exo cage mounting points must attach to the exterior of the body or chassis (including sliders, bumpers, etc)
- Cage must have down bars and cross bars in front and behind each row of seats at a height which would protect a full 5.5" tall figure sitting in a normal position
- Cage(s) cannot flex under the weight of the rig if rolled
- Cage must be a rigid material of at least 0.125" (3.2mm) diameter that is permanently brazed, welded, soldered or mechanically fastened together, to create a single unit
- A vehicle interior or interior cover is required to receive interior cage points
- Interior and Exo Cage points are not available to tubers
- Points applied per row of seats or area where seats should be
 - The bed of a truck doesn't apply to cage points if seats are present

METAL POINTS: -3 (MAX -9)

TUBE / PLATE ACCESSORIES

- Must meet the respective rectangle requirements of the specific Class
- Must be made from a rigid material
 - Tube must be 0.125" (3.2mm) diameter or more
 - Flat plate may be any thickness with a minimum width of ½" overall
 - IE, it can be bent but two measured sides must equal at least ½"
 - Smaller material may be used, but will not count towards points

SLIDERS

- Must meet the Center Rectangle requirement for length
- Can't be higher than the top of the wheel measured at full compression for its entire length
- Must be mechanically fastened, welded, or brazed to the chassis
- Must protect the bottom edge of the body (body armor does not count as a slider)
- Must be rigid enough to support the entire weight of the vehicle without flexing or changing shape.
- Must have sliders on both sides of rig to receive points
- Points are awarded if present on both sides of the vehicle

METAL POINTS: -3

PLASTIC POINTS: -1

BUMPERS

- Metal bumpers must be chassis mounted and separate from the body to receive points
- Plastic bumpers can be mounted to a hard body to receive points
- Must meet Rectangle requirements for its class
- Only one front and one rear bumper are allowed

METAL POINTS: -3 EACH

PLASTIC POINTS: -1 EACH

STINGER / GRILL GUARD

- In addition to bumper points
- Does not count as a fairlead
- Must be mounted to the bumper

POINTS: -1

FABRICATED SHOCK MOUNTS

- Must be made of metal and brazed or welded to the chassis
- Must be in pairs

POINTS PER PAIR: -1

ROOF RACK

- Must be mounted off the roof at least .125" (3.2mm)
- Must have minimum .125" (3.2mm) thickness
- Must meet or exceed a minimum of 2" by 3" rectangle

METAL POINTS: -2

PLASTIC POINTS: -1

LIGHT BAR

- Must be mounted above windshield or on top of the roof/roll bar
- Minimum width 3" (76.2mm)
 - reason: Matches minimum roofline coverage requirement

POINTS: -1

INTERIOR

FULL INTERIOR

- Must have a full floor and firewall bulkhead (Driver's feet must not poke out into open chassis or wheel well)
- Must have all of these 3-dimensional features:
 - seat(s), dash and steering wheel
- Must be proportionately sized to accommodate a complete 5.5" human figure
- All partial figures shall be of similar scale to a complete 5.5" figure
- Must have a minimum depth of 1" from the lower windshield frame/cowl to the floor

1 SEAT POINTS: -3 OR -5 IF CUSTOM

2 SEAT POINTS: -4 OR -6 IF CUSTOM

4 SEAT POINTS: -5 OR -7 IF CUSTOM

INTERIOR COVER

- Interiors that do not comply with “full interior” specifications
- A molded in driver will receive an additional -1 and no points for passengers

1 SEAT POINTS: -1

2 SEAT POINTS: -2

4 SEAT POINTS: -3

MOLDED IN DRIVER: -1

SUV CARGO AREA

- Must have a minimum depth of 1” from bottom of the window to the floor
- Points available For SUV bodies only (Not pick-ups)

POINTS: -1

DRIVER/PASSENGER

- A complete figure must be a minimum of 5.5" tall
- All partial figures shall be of similar scale to a complete figure
- Full interior required to receive these points

- Maximum 2 figures

FULL FIGURE POINTS: -4

KNEES UP ONLY POINTS: -3

WAIST UP POINTS: -2

ARMS UP POINTS: -1

SUSPENSION, DRIVETRAIN, AND STEERING

LEAF SPRINGS

- Must Support vehicles weight without external shock springs

1 AXLE POINTS: -3

2 OR MORE AXLES POINTS: -7

MULTIPLE DRIVEN AXLES

3 AXLES POINTS: -3

4+ AXLES POINTS: -4

CHASSIS MOUNTED STEERING SERVO

- Rear CMS points are only available in Class 3

FRONT CMS POINTS: -5

REAR CMS POINTS: -2

FUNCTIONING TRANSFER CASE

- Transfer case points are awarded when a transmission is present that has gear reduction from the motor and a different set of gears is dividing the power to the axles
- Standalone factory 3 gear transmissions do not count for transfer case points

POINTS: -4

3D ENGINE

- Must be in a reasonable location and appear to be powering the drivetrain of the vehicle
- Must resemble a complete engine
- Anything that does not meet the above criteria is an engine cover

POINTS: -4

ENGINE COVER: -1

SCALE ACCESSORIES

- Windshield wipers, opening hood, doors. Head and tail lights, winch (incl line and fairlead), sand ladders, tow strap, Fuel cell, exhaust, jerry can, hubs on all wheels, steering stabilizer, disc/drum brakes on all wheels, mirror(s), wiper(s), antenna, license plate, first aid, extinguisher, trail tools, hi-lift jack, etc...
 - Only count -1 point for multiple items (except winches)
 - Points are allowed for front and rear winch

SCALE POINTS -1 EACH (NOT TO EXCEED -14)

SPARE TIRE(S)

- Must remain functional (mounted to a rim)
- Must be within .25" diameter of the drive tires

POINTS: -3

COURSE POINTS

SORRCA provides a standardized set of course points to be used for the running of events under SORRCA rules to maintain consistent scoring of a participant's course driving. A standard course consists of 10 gates numbered 1-10 and can also have bonus gates.

Points System:

Gate Progress: -2 points

Bonus Gate Progress: -5 points (awarded only on course completion)

Back-up / Reverse: +1 point

Self-Recovery (Winching/Sand ladders/Jacks): +3 points

Rollover: +5 points

Gate Marker: +10 points

Boundary Marker: +10 points

Course Direction: +10 points

Assisted Recovery: +10 points

Winch Stick

Vehicle Touch / Repositions / Repair: +10 points

Safety (Time out)

Vehicle out of spec (Time out)

Point out: +60 points minimum

Did not finish: Point out + 20 - progress

Did not start: Point out + 50 points

Course Time Allowed: 6 minutes minimum

GATE PROGRESS (-2 POINTS)

Gate Progress shall be awarded to drivers for each gate that is cleared by the vehicle during the attempt of a course

- A gate is considered cleared and progress points shall be given when at least one front and one rear tire passes completely through the gate in the intended direction of the gate in the same attempt
 - A single tire is required to be in contact with the ground between the gates during the attempt
 - Contact between the gates is defined as tire contact at any point for any duration
 - Both trailing edges of the tires from the last axle to progress the gate must clear the trailing edge of the gate to receive clean progress
 - Taking a gate is defined as straddling or intentionally hitting a gate to achieve progress
 - If the driver is taking the gate or hits a gate, only 1 tire from each axle is required to pass the trailing edges of the gate for progress
- "Gate Progress" points are deducted from the total course score after completing the attempt on the course

BONUS GATE PROGRESS (-5 POINTS)

Bonus Gate Progress shall be awarded if the participant clears a bonus gate:

SORRCA RULES 2023

- The event organizer may have bonus gates on the course. A “*Bonus Progress*” shall be awarded if the gate is progressed as described in the Gate Progress description
- Bonus Gates may only be progressed once per course attempt and will have a marked direction of travel
- Bonus gates markers count as a gate marker penalty when hit
- Bonus gate progress does not count towards your points unless you finish the course

REVERSE (+1 POINT)

Reverse penalty is given when a tire spins in the reverse direction

Reversing is defined as:

- Any time the tire(s) spin/rotate in the reverse direction, whether engaged or freewheeling, intentional or not
- Once a reverse penalty is given, no further reverse penalty will be given until the tires rotate forward
- No penalty is given if the vehicle has rolled more than 90 degrees from the crawling surface
- Vehicles that land back on their wheels without assistance are not penalized, no reverse penalties will be awarded until the vehicle is righted
- If a driver begins a course in reverse, a reverse penalty will occur immediately
- The vehicle sliding backwards without the tire(s) rotating in a reverse direction does not constitute a “Reverse” penalty

SELF-RECOVERY (+3 POINTS)

Self-recovery: penalty will be given every time the vehicles winch cable is connected/reconnected to an anchor point or self-recovery tools are positioned/repositioned

- If at any time during the process of removing or replacing recovery tools and/or winch line from vehicle, the vehicle is moved (pushed, pulled, or slid from initial position) by any force other than the winch or its own power, a “*vehicle touch*” penalty will be given, and associated rules apply
- All self-recovery tools (sand ladders, tow straps, pullpals etc.) must be carried on the vehicle and replaced after recovery is completed otherwise “*Vehicle Out of Spec*” will be called by the judge and an “On Course Repair” or “Off Course Repair” will be given and associated rules apply
- When winching you must set your anchor/hook/etc and not be touching it or the line before the truck moves otherwise a touch repo is called

ROLLOVER (+5 POINTS)

Rollover penalty is given when a vehicle is rolled over by hand as per below:

- When a vehicle has rolled beyond 90 degrees from the crawling surface and cannot be self-righted back on to its tires the participant can perform a roll-over as described below
 - The rig may only be rolled over in one direction to the passenger side or driver’s side at the driver’s digression (Not end over end)
 - By holding it by the chassis or body roll the vehicle over (Rolling from the tires suspension of axles will be a “*vehicle touch*” penalty and associated rules apply)

SORRCA RULES 2023

- The vehicle must remain in contact with the ground and may be rolled a maximum of 360 degrees
- The vehicle must not be slid, rotated, or twisted while performing a roll-over (If the vehicle orientation changes other than a sideways roll it will be considered a “*vehicle touch*” penalty and associated rules apply)
- If the vehicle cannot maintain a stable position without the participant holding the rig in place it will be considered a “*vehicle touch*” penalty and associated rules will apply

GATE MARKER (+10 POINTS)

Gate Marker penalty will be given when:

- When a gate marker is touched by any part of the vehicle, a tow strap, winch line, etc
- Each gate marker can incur a 10-point penalty
- Receiving a Gate Marker penalty will not stop the course timer or the course run attempt unless doing gives the driver +80 points or more

A gate marker will remain “*live*” for the entire duration of the attempt on the course until it is considered a “*dead*” gate marker. Once a Gate marker is considered “*dead*”, no further penalties will be assessed for that gate marker. A gate marker is considered “*dead*” when:

- The gate marker has been touched or straddled
 - Straddle is defined as tires from an axle are on either side of the gate in contact with ground
- There will no longer be a penalty for accidentally stepping on a gate for anyone (for safety reasons) but please stay off course as much as possible and limit course damage
- Regardless if a gate is considered “*dead*”, a vehicle must still achieve a gate progress (see Gate Progress rules) in order to proceed to the next gate in sequence
- If a gate marker is determined to be out of position during the course run a stop time is called and the gate is restored and the truck will continue from its current spot once time resumes

BOUNDARY MARKER (+10 POINTS)

Boundary Marker penalty is given when:

- Any part of the vehicle, tow strap or winch line touches a boundary marker
- Once a boundary marker is touched the judge will stop time and the driver will move the vehicle back to the last gate cleared following the “*reposition*” process
- Boundary markers are always live even after being touched

COURSE DIRECTION (+10 POINTS)

Course Direction Gates must be cleared in their intended direction and sequence

If the vehicle progresses an un-cleared gate in the wrong direction, or out of sequence will result in a 10-point penalty and the judge will stop time:

- Time will be stopped and the vehicle is then moved back to the previously cleared gate (*see reposition process*)
- Once a gate is cleared and awarded progress it can be traveled in any sequence or direction

- If for some reason any gate(s) is/are missed and the final gate is progressed a penalty for both gate markers and no progress will be awarded for each missed gate
- Gates can be progressed driving forward or reverse through the intended direction

ASSISTED RECOVERY (+10 POINTS)

Assisted Recovery: This is for the new drivers that don't have a winch, if you have a winch installed this section does not apply

- The stranded vehicle shall not be pulled beyond the original position of the rescuing vehicle, or it will result in another "*assisted recovery*" penalty
- **Self-Retracting winch / Bungee winch** will count as an "*assisted recovery*". If the vehicle is pulled without driver input to the vehicle a "*vehicle touch*" penalty will be given additionally, and associated rules apply
- Pulling the vehicle by hand with any cable or line will be a "*Vehicle Touch*" penalty and associated rules apply

WINCH STICK

Winch stick use must be declared as available or not available on the event page – they are not mandatory, but declaring if they are available for use is mandatory before tickets are sold

Winch sticks may be used on the course:

- Sticks are provided by the event coordinator. Non-event provided winch sticks may not be used under any circumstances
- The winch stick may be of any length but must have a mark 6" from the grounded end of the stick
- A hook or anchor point can be added but cannot be higher than 6" from the grounded end

Use of the winch stick:

- Will follow Self recovery rules in addition to below
 - Must be held firmly against the ground and maintain a vertical position.
 - Cannot slip or lose original position or attitude from when vehicle winch was attached.
 - Vehicles winch line or connection method cannot be attached higher than the 6" mark of the stick
 - If the winch line becomes disconnected another "*self-recovery*" penalty will be given if reconnected
 - "*Vehicle touch*" penalty will be given and associated rules apply if:
 - The vehicle touches the winch stick
 - The winch stick is placed in a manner to block or be used as a barricade from falling, rolling, or touching a gate/boundary
 - The winch stick moves from its initial position/ attitude while the winch line is connected
- If the winch stick fails, time stops, this is not on the driver and the host will get a new stick – The truck will be repositioned and reattached at the point of failure with no penalty

VEHICLE TOUCH (+10 POINTS)

Vehicle touch penalty is given when the participant incurs the following:

- All vehicle touches whether intentional or unintentional, are given an automatic +10 points penalty
- Vehicle touches include but are not limited to: repairs, repositions, vehicle driving/falling into the driver
 - excluding “rollovers”, “winching”, “assisted recoveries” (*see associated rules*),
- When the judge or driver calls a vehicle touch and reposition will occur following the reposition process

REPOSITION (+10 POINTS)

Reposition penalty is given if the driver calls for a vehicle reposition and the vehicle is then moved back by the driver to the previously progressed gate (bonus gates count as last gate cleared also) with at least one tire between the gate markers

- The Judge will stop the course timer
- The vehicle will be placed at the last gate progressed
 - If at least one tire cannot be placed between the gate markers due to course design, the judge will reposition the vehicle to the next stable location at the last progressed gate (This location will be used for all drivers)
 - Note: All gates for progress are still “live” unless a gate has already been deemed “dead”
- Time will start when the driver resumes driving or at the Judge’s discretion

ON-COURSE REPAIRS (+10 POINTS)

On-Course repair penalty is given if the driver chooses to repair their vehicle due to it being damaged or becoming out of specification while on the course:

- Judge determines the vehicle has become out of spec or driver calls for on course repairs
- Repairs are done on the course where the Judge/Driver determined the vehicle needed repair
- The course timer will continue to run, and repairs must be made within the course time
- There are no restrictions on whom or how the repairs are made
- If repairs are made within the course time:
 - The Judge will stop time and Judge/Marshal will determine if the vehicle is in spec
 - With time stopped, the vehicle will be repositioned following the reposition process
 - Time will start when the driver resumes driving or at the Judge’s discretion
- If repairs cannot be made within the course time, the driver is given a Did Not Finish penalty (see associated rules)

OFF-COURSE REPAIRS (+10 POINTS AND 1 MINUTE)

Off Course Repair penalty is given if the driver chooses to repair their vehicle due to it being damaged or becoming out of specification, with time stopped and off the course:

- Repairs are to be completed off the course
- The course timer will be stopped and 1 minute penalty will be subtracted from the time remaining to run the course
- Repairs should be completed within 30 minutes (or as determined by the event organizer at the driver's meeting)
- If repairs are made within the allotted repair time:
 - The Judge/Marshal will determine if repairs are adequate
 - A reposition will take place following the reposition process
 - Time will start (with the 1-minute deduction as above) when the driver resumes driving or at the Judge's discretion.
- If repairs are unsuccessful within the allotted time the driver is given a Did Not Finish penalty (see associated rules)

SAFETY (TIME OUT)

Safety Time Out may be called by the driver for time to stop so that they may safely reposition themselves on the course

- This time out shall be used for the purpose of driver safety
- This time out may not be used to survey the course or for any other advantage
- Once the competitor is repositioned the time will start, however the judge has the right to restart time at any point
- The judge can determine if this is being abused and deny the request

VEHICLE OUT-OF-SPEC (TIME OUT)

Vehicle out-of-spec (time out) may be called by the Judge if they have reason to believe a vehicle is out of spec during a course run. At the time the Judge calls for Vehicle out of spec (time out):

- Course timer is stopped
- The driver must stop driving the vehicle – no additional inputs maybe given by the driver to the vehicle via touch or radio control
- The Judge must mark the vehicle's location and perform a tech inspection as specified in the "General Vehicle Specifications" (*same manner as all other tech inspections*)
- If the vehicle has been deemed within spec, the driver will return the vehicle to the location marked by the judge and the course timer will start once the driver resumes driving the vehicle
- If a vehicle falls out of spec due to breakage on course and the judge determines the driver has not gained an advantage, then the driver may resume the attempt on the course at the last position before stopping time without any time or points penalties
- If the vehicle is now out of spec and/or the Judge has determined that the vehicle has gained an advantage, the driver must take a repair to correct the problem. The driver may choose to do an "On Course Repair" or "Off Course repair" and the associated rules apply
- Any of the below are considered out of spec:

SORRCA RULES 2023

- Changes not meeting the rectangle parameters for its class and creating an advantage.
- Bodies, body panels coming off or out of place
- Any “scale items” falling off the vehicle also constitute a vehicle becoming out of spec, and must be repaired immediately
- This includes electronics/batteries becoming visible

POINT OUT (+80 POINTS)

The maximum penalty points accumulated on a course attempt is +80 points. If a driver accumulates 80 penalty points their attempt on the course immediately ends and they will receive a “DNF (Did not finish)”

DNF (DID NOT FINISH) (POINT OUT +20 POINTS)

DNF is given anytime a driver cannot complete a course either by a point out or running out of time

A driver score after a **DNF** is tallied as follows:

- Driver receives DNF points (80 penalty points +20 demerit points)
- All regular progress points prior to the DNF are awarded to the score
 - Bonus Progresses are not counted if the driver DNFs
- ½ Scale points (as tech’d in) are awarded to the score

DNS (DID NOT START) (POINT OUT +50 POINTS)

DNS is given anytime a driver cannot start a course for any reason:

- The Vehicle cannot start course under its own power
- The Driver does not attempt the course within the events scheduled time
- No scale points will be awarded to this course

A driver’s score after a **DNS** is tallied as follows:

- Driver receives DNS points (+80 Point out +50 demerit points) +130 Points